

## PD Plus®

### Model 1200 Heavy Duty

Bi-directional Rotation

Series Options:

Horizontal Air Service

Vertical Air Service

Horizontal Flow, Single Envelope Gas Service

Vertical Flow, Single Envelope Gas Service

Horizontal Flow, Double Envelope Gas Service

Vertical Flow, Double Envelope Gas Service

Model 1200 PD PLUS heavy duty industrial blowers are designed for high performance applications, up to 15 PSIG pressure boost or 15" Hg dry vacuum (24" Hg water injected).

#### Vertical & Horizontal Air Flow

This series has wide application in pneumatic conveying, wastewater treatment and the general process industry where high pressure, high volume air is required. Seal areas are vented to atmosphere to relieve process pressure against the internal lip seals, and to provide oil-free air.

#### Vertical & Horizontal Single Envelope Gas Service

This series is utilized in such applications as closed loop pneumatic conveying, process gas handling, or elevated pressure applications up to 100 PSIG discharge. Vent openings are tapped and plugged to prevent gas leakage. These fittings can also accept an inert gas purge for positive containment of the process gas.

#### Vertical & Horizontal Double Envelope Gas Service

This series is built to laboratory standards where virtually complete sealing is required. In addition to the features shown on series above, the drive shaft is mechanically sealed and the oil sumps are plugged to provide an even higher degree of leakage protection.

#### Special Materials

Stainless Steel\*

Carbon Steel\*\*

Ductile Iron\*\*\*

\*1224 only \*\*1224 only \*\*\*1236 & 1248 only

#### Special Coatings

Bi-Protec® (Nickel/Armoly®)



Model Size	Max. Press. PSI	Max. Vac. (in. Hg)	Nom. Min. RPM at Max. Disch. Pressure	Nom. Max. RPM at Max. Disch. Pressure	Displ. CFR
1215	15	15	840	1800	2.209
1224	15	15	800	1800	3.534
1230	14	15	700	1800	4.418
1236	9	12	450	1800	5.301
1248	6	10	400	1400	7.068

#### Material Specifications:

**Housing:** Cast iron

**End Plates:** Cast iron

**End Covers:** Cast iron

**Rotors:** Ductile iron

**Shafts:** Ductile iron cast integrally with rotor

**Bearings:** Rotor shafts - Double row ball

Drive shaft - Spherical roller

**Drive Shaft:** SAE 4140 forged alloy steel

**Gears:** Heat treated alloy steel, helical cut

**Seals:** Standard - Lip and labyrinth type on rotor shafts; lip seal on the drive shaft

Single Envelope Gas Service - Mechanical and labyrinth type on rotor shafts; lip seal on the drive shaft

Double Envelope Gas Service - Same as Single Envelope series plus mechanical sealing on the drive shaft

**Lubrication:** Bearings are lubricated by an integral pressure system including filter and oil to water heat exchanger; gears are splash lubricated.

\* Blowers operating with a discharge pressure above 20 PSIG require mechanical rotor shaft sealing; above 25 PSIG requires hydrostatic testing and special high pressure seal leakage testing.

## Performance Tables

In conjunction with our program of continuous testing and design upgrading, all specifications are subject to change without notice. All data are approximate. Request a quotation for your specific application.

### Pressure (14.70 PSIA and 70° F Inlet)

BLOWER MODEL	SPEED (RPM)	2 PSIG		6 PSIG		9 PSIG		10 PSIG		12 PSIG		14 PSIG		15 PSIG		Max. Vacuum		
		CFM	BHP	CFM	BHP	CFM	BHP	CFM	BHP	CFM	BHP	CFM	BHP	CFM	BHP	In. Hg	CFM	BHP
1215	600	1025	15	806	38	689	56	655	61							12	661	38
	1200	2351	30	2131	77	2015	111	1980	123	1916	146	1857	169	1829	181	15	1836	93
	1800	3676	46	3457	115	3340	167	3306	184	3242	219	3183	254	3155	271	15	3161	139
1224	600	1661	22	1324	59	1145	87	1092	96							13	1027	63
	1200	3781	44	3444	118	3265	174	3213	192	3115	229	3024	266	2982	285	15	2991	144
	1800	5901	66	5565	177	5385	261	5333	288	5235	344	5145	399	5102	427	15	5111	215
1230	600	2076	27	1655	73	1431	108	1365	119							13	1284	78
	1200	4727	54	4306	146	4082	215	4016	238	3894	285	3781	331	3727	354	15	3739	178
	1800	7378	80	6957	219	6733	323	6667	358	6544	427	6432	496			15	6390	267
1236	600	2506	31	2012	87	1749	129									12	1685	85
	1200	5686	63	5193	174	4930	257									12	4866	171
	1800	8867	94	8373	261	8111	385									12	8046	256
1248	600	3361	41	2717	115											10	2552	94
	1200	7602	81	6958	229											10	4524	189
	1400	9016	95	8372	267											10	8206	220

## Dimensions

Horizontal Flow, Single Envelope Gas Service

Vertical Flow, Single Envelope Gas Service

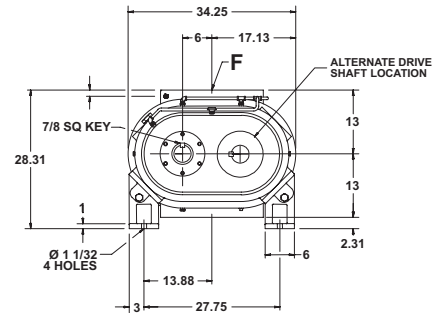
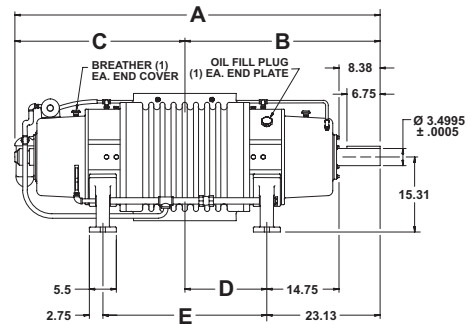
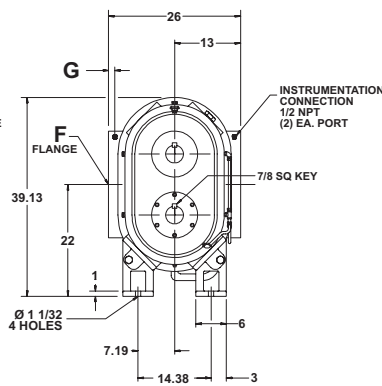
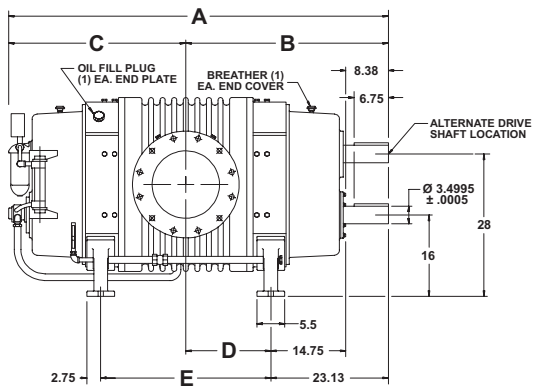

Values are approximate and should not be used for construction. Certain dimensions for Double Envelope Gas Service series may slightly differ from dimensions shown. Certified prints are available through your local Tuthill Vacuum & Blower Systems Sales Professional.

\*Approximate shipping weight.

Your Local Tuthill Vacuum Blower Systems Sales Professional:



Tuthill Vacuum & Blower Systems  
 4840 West Kearney Street  
 Springfield, Missouri USA 65803-8702  
 o 417.865.8715 800.825.6937 f 417.865.2950  
 tuthillvacuumblower.com



TH-047 12/16